

Tolerance Grade	Dimension	0.5-3	3-6	6-30	>30-120	>120-400	>400-1000	>1000-2000	>2000-4000
GB/T1804-m(Medium)		±0.1	±0.1	±0.2	±0.3	±0.5	±0.8	±1.2	±2
GB/T1804-r(Rough)		±0.2	±0.3	±0.5	±0.8	±1.2	±2	±3	±4

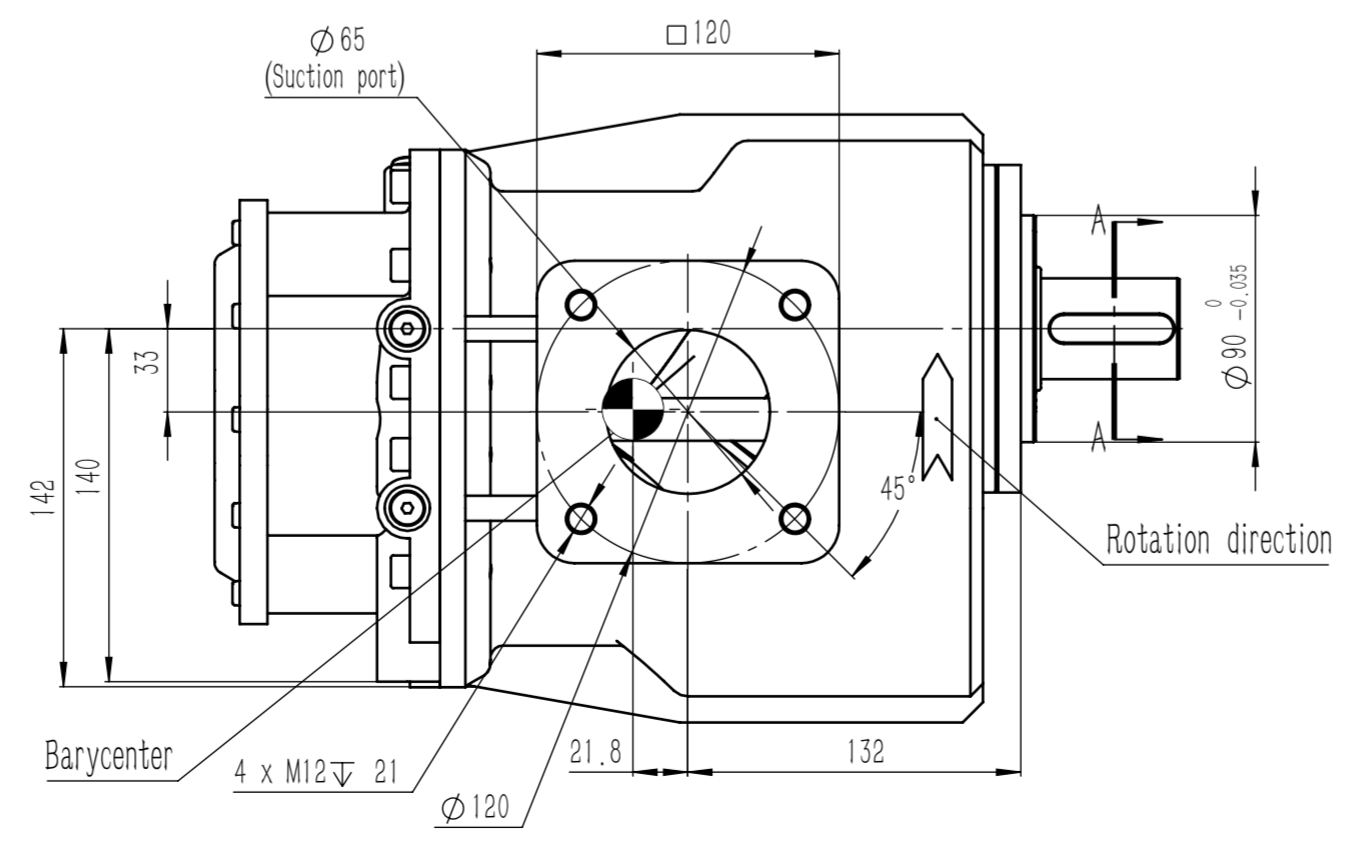
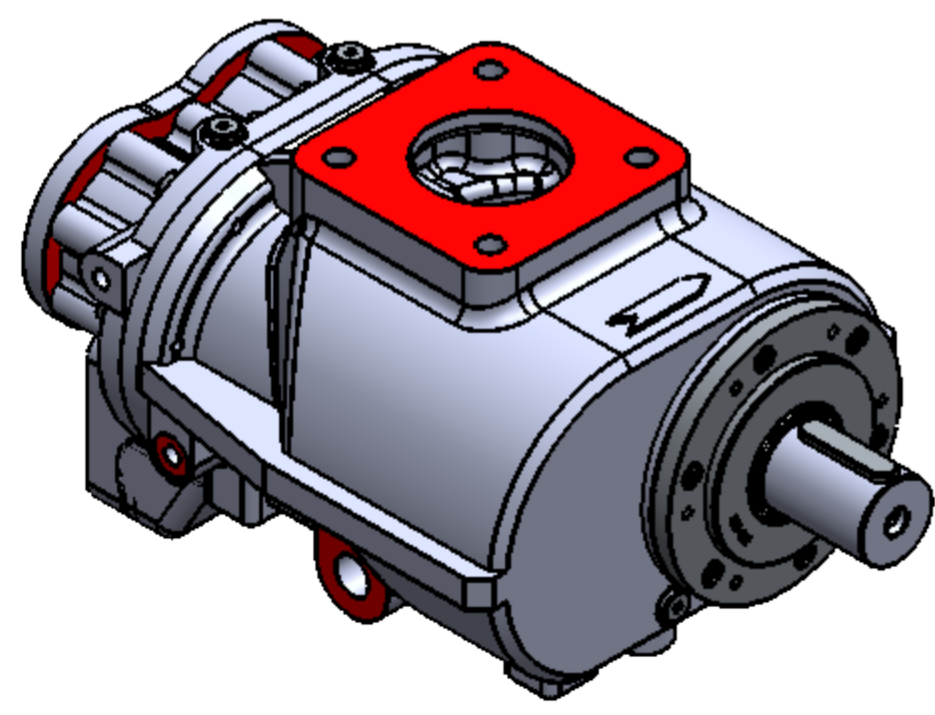
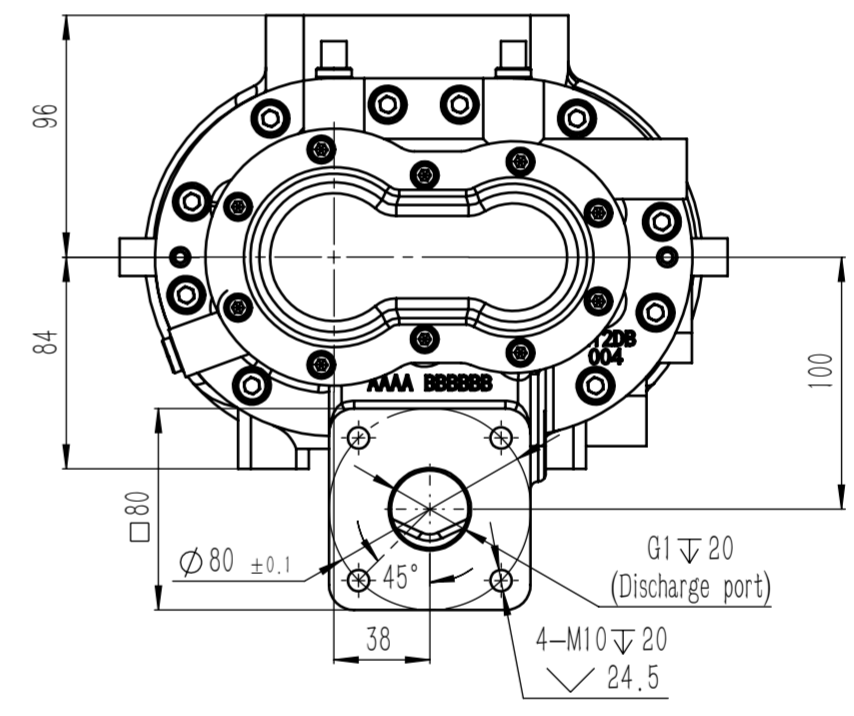
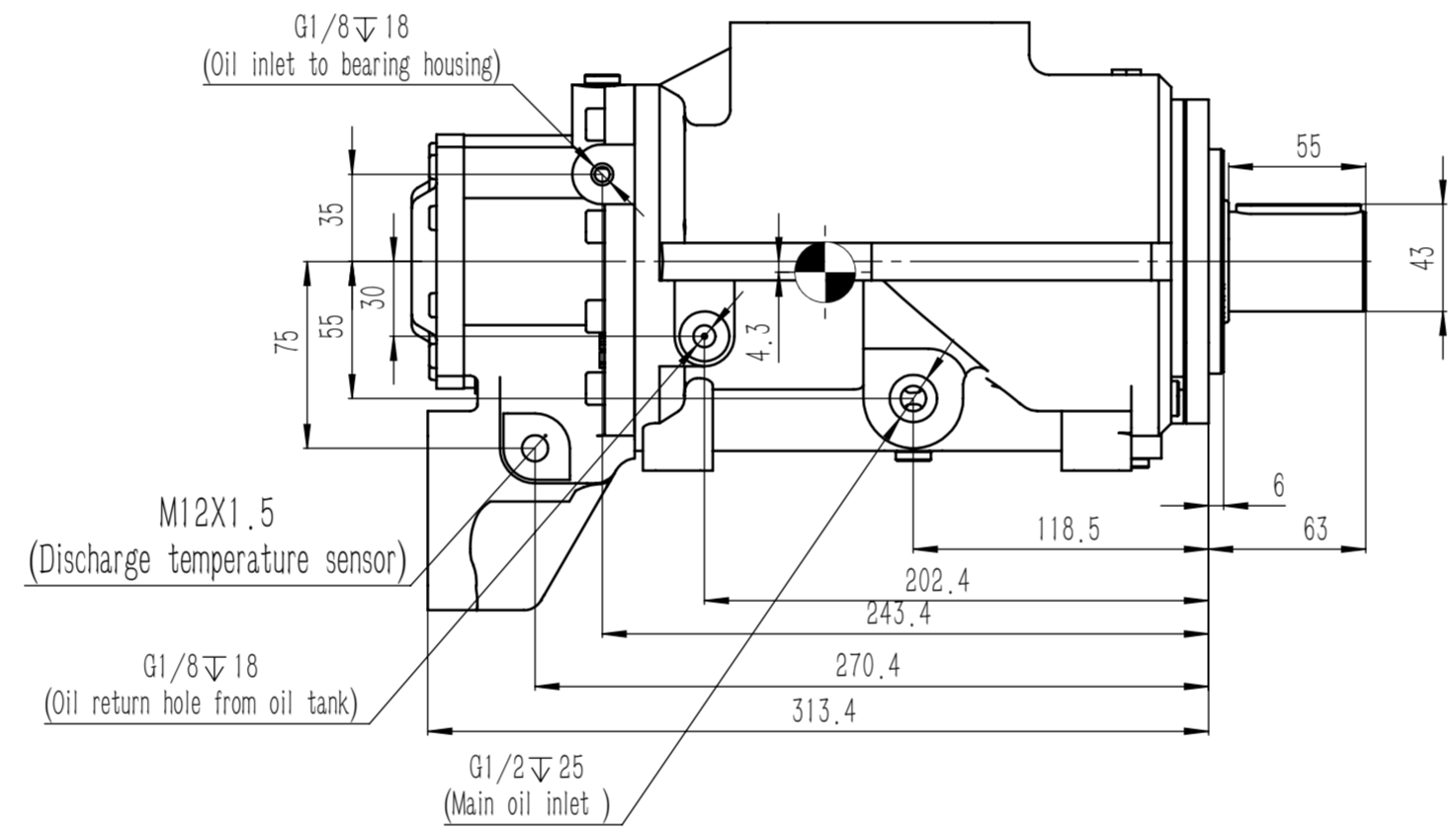
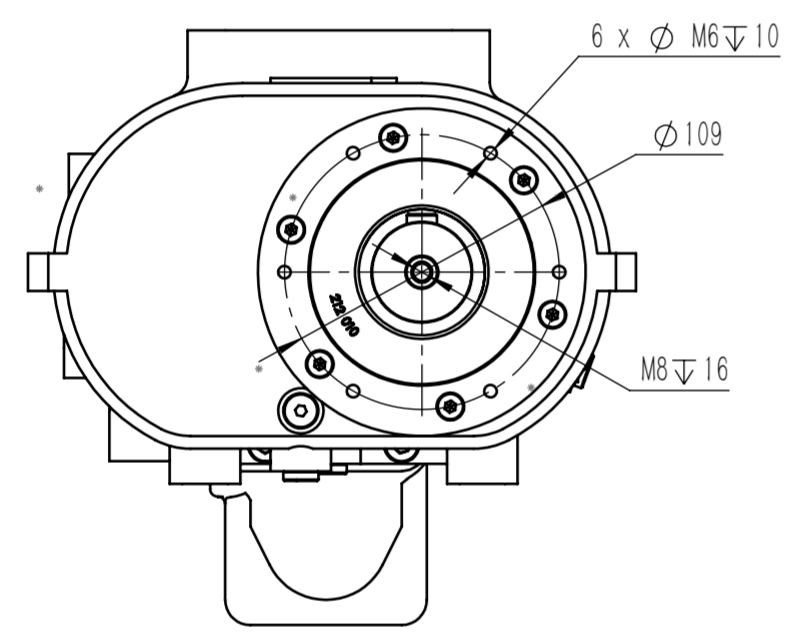
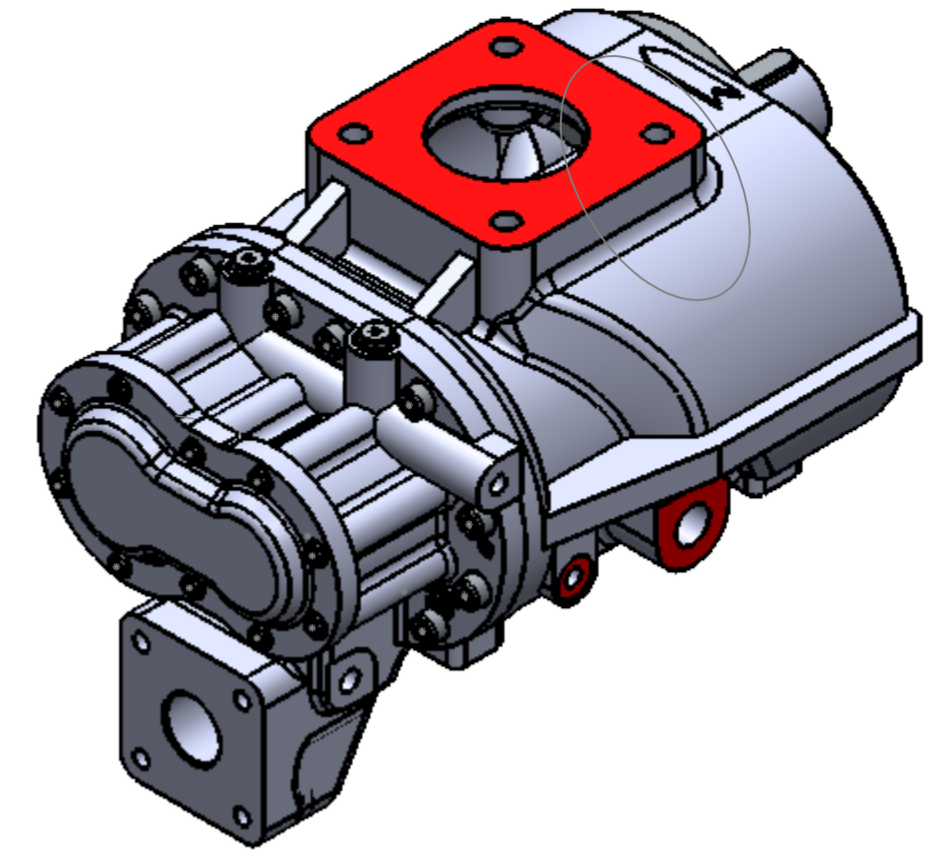
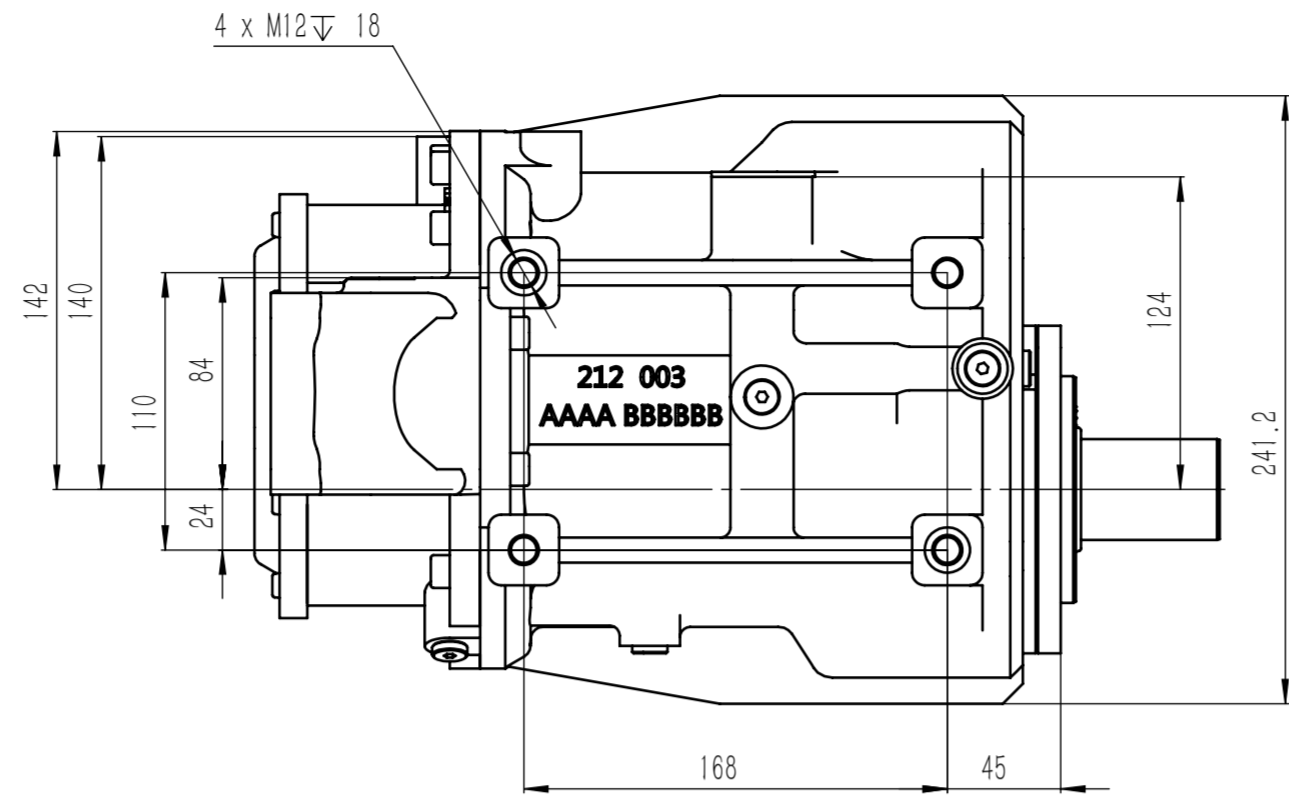
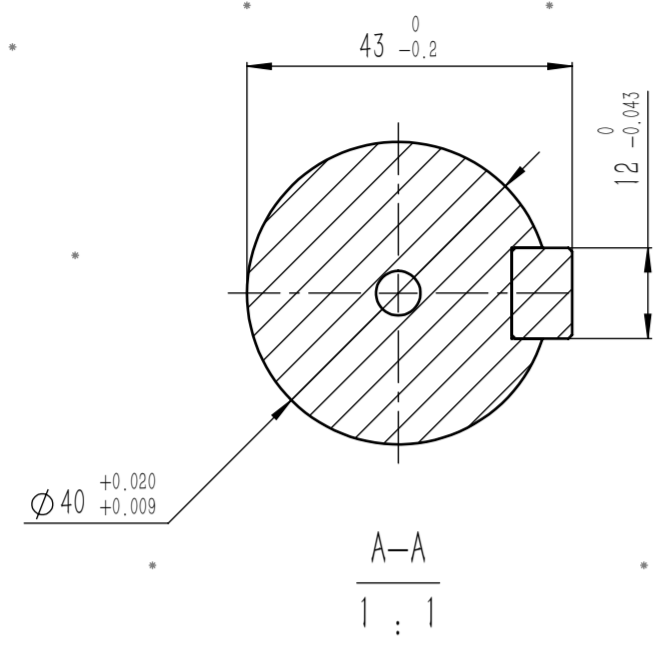

Requirement

1. Direct driving screw compressor.
2. Shaft end tapping is strictly prohibited.
3. No reversal.
4. Fill some lubricant from suction flange before start up.
5. To avoid extra noise when unloading, compensation air should be considered.

NO.	Partition	Charge NO.	Sign	Date	Version Tag	Weight	Scale	AZT 72
Design	ZH	2021.02.24	Standardization		A01	38.65	1,5	
Revision								
Audit								
Process			Approve		Sheet 1	of 1		